

Color Notes

COLOR INDEX

- PLOT BOUNDARY
ABUTTING ROAD
PROPOSED WORK (COVERAGE AREA)
EXISTING (To be retained)
EXISTING (To be demolished)

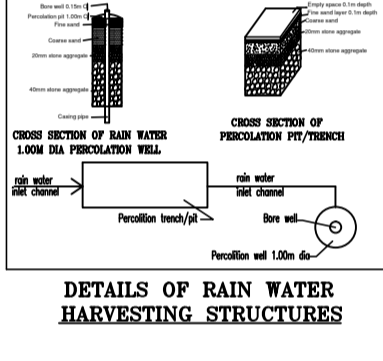
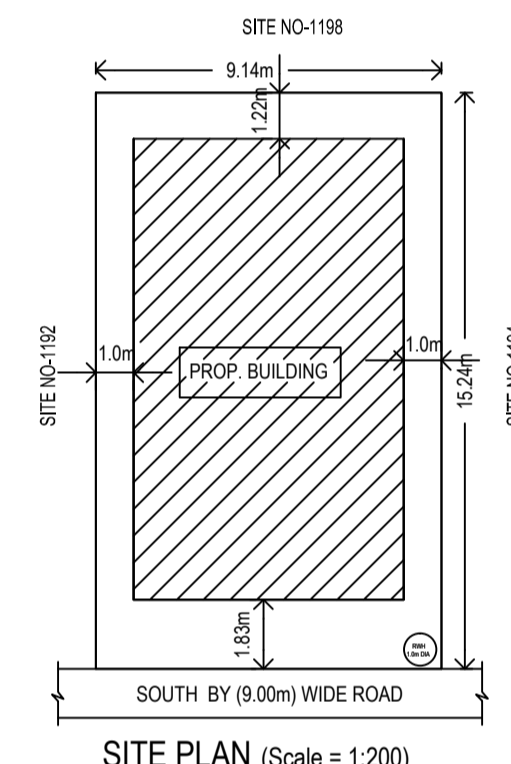
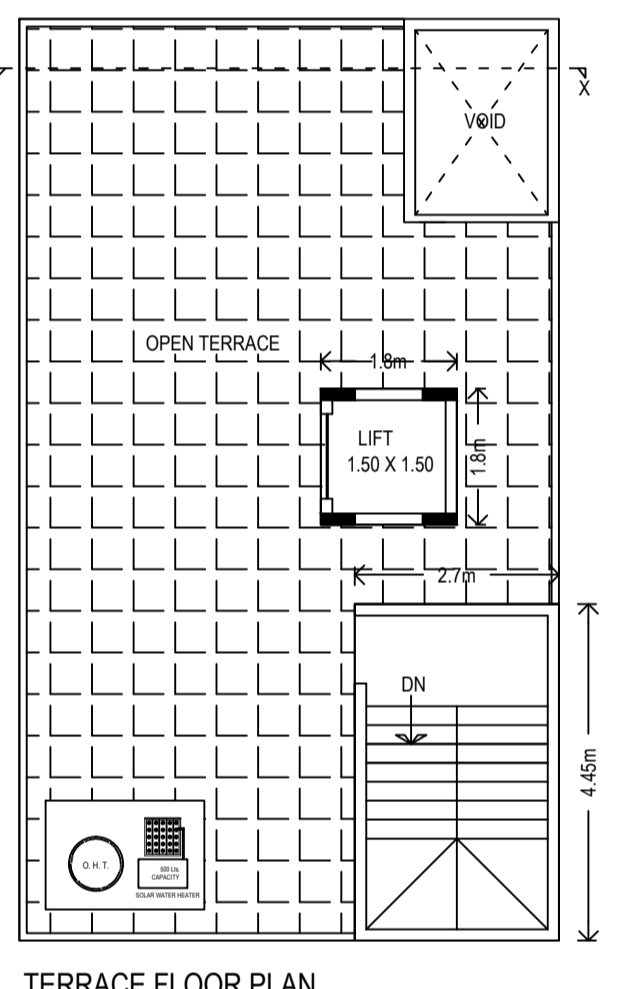
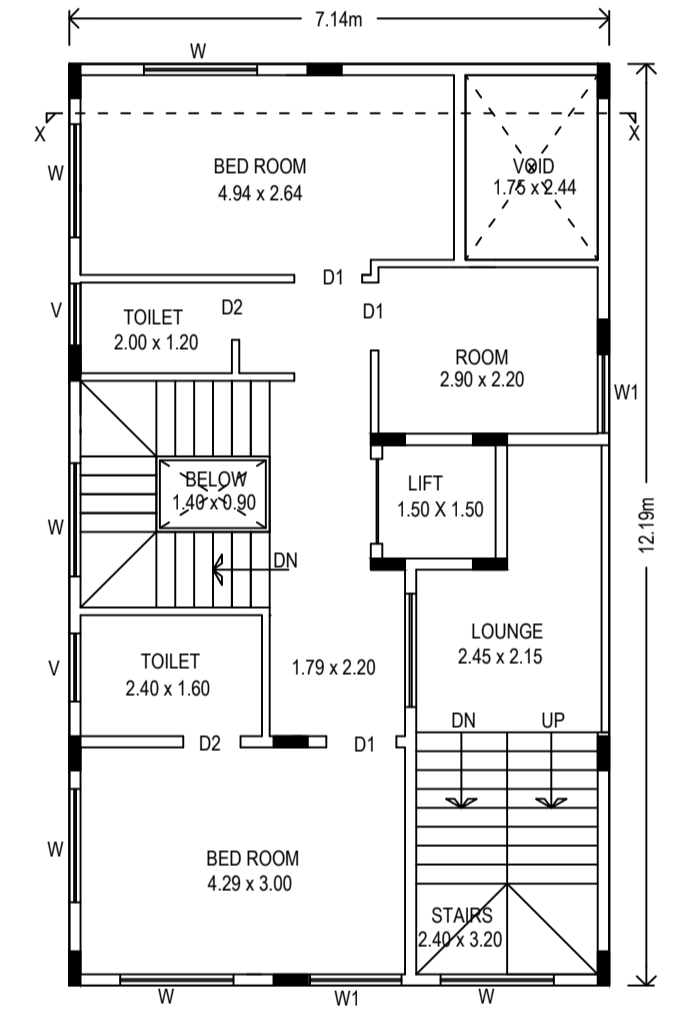
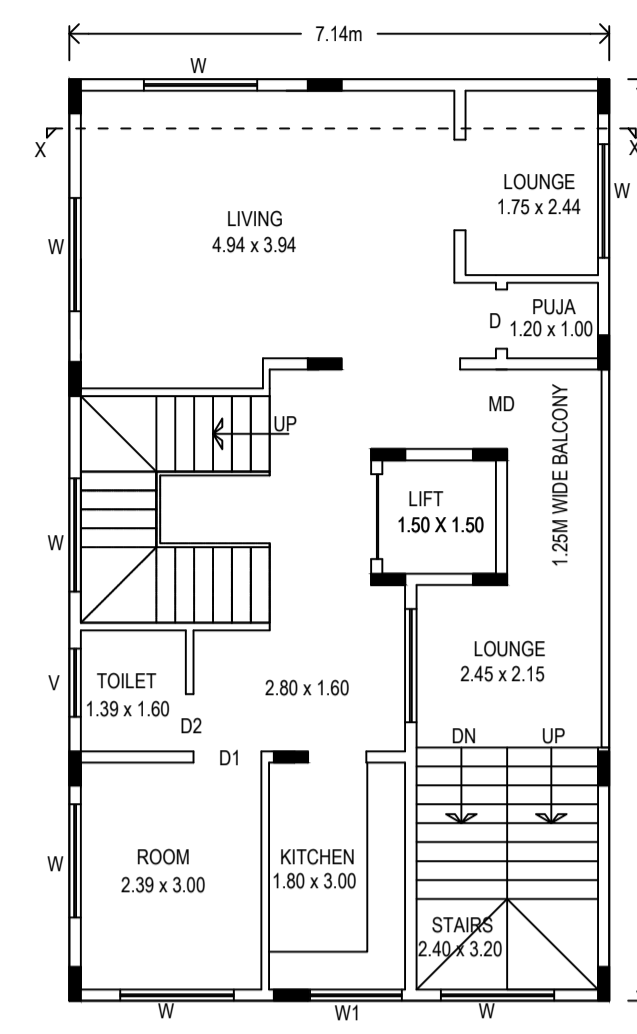
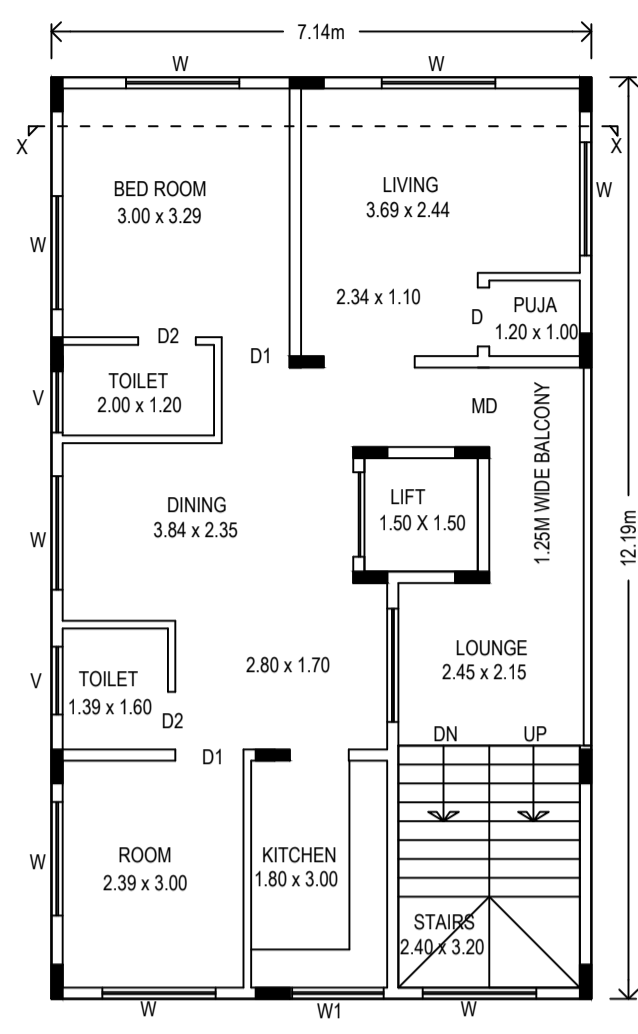
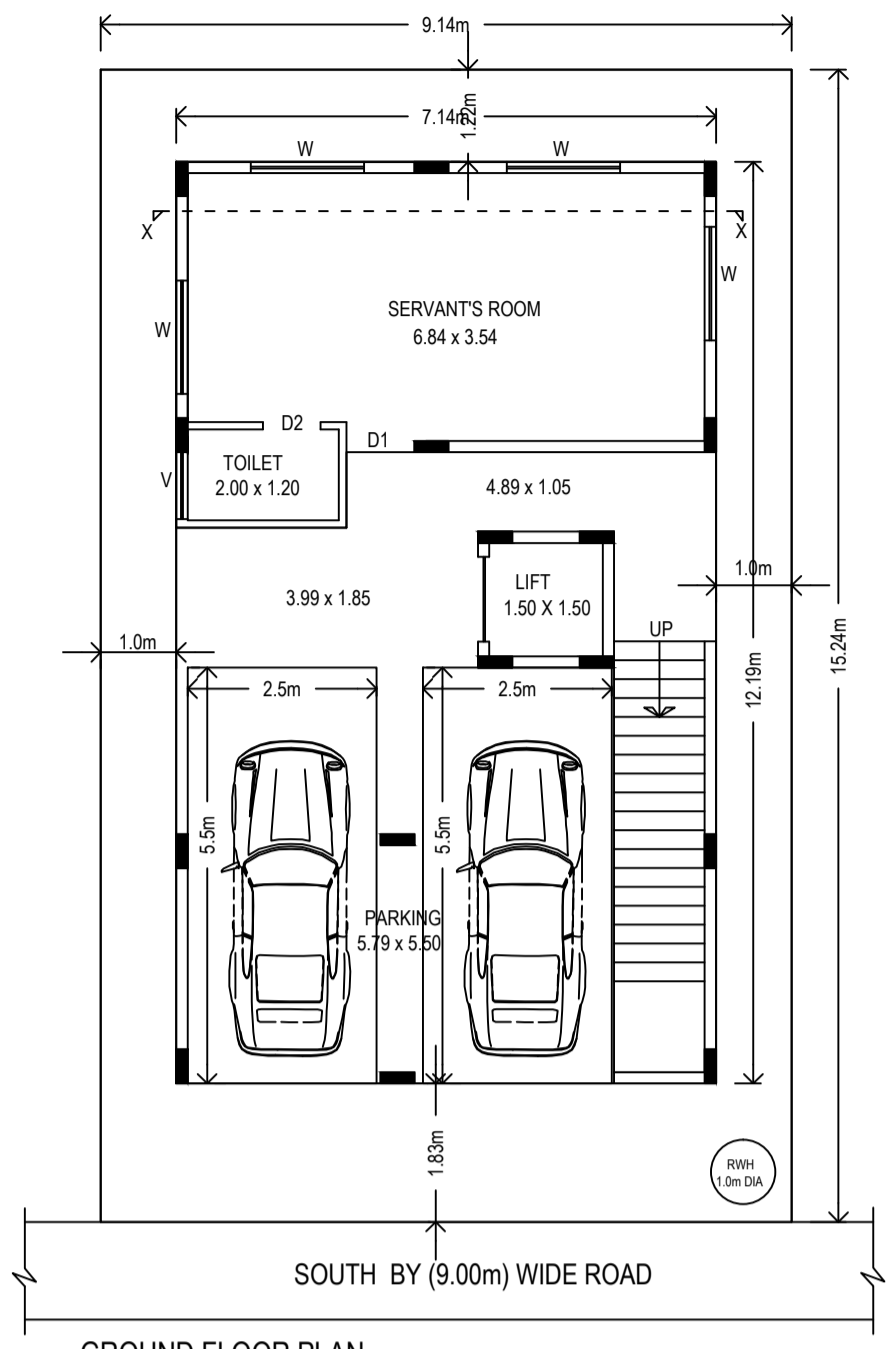
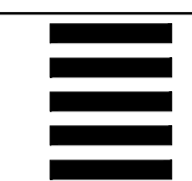
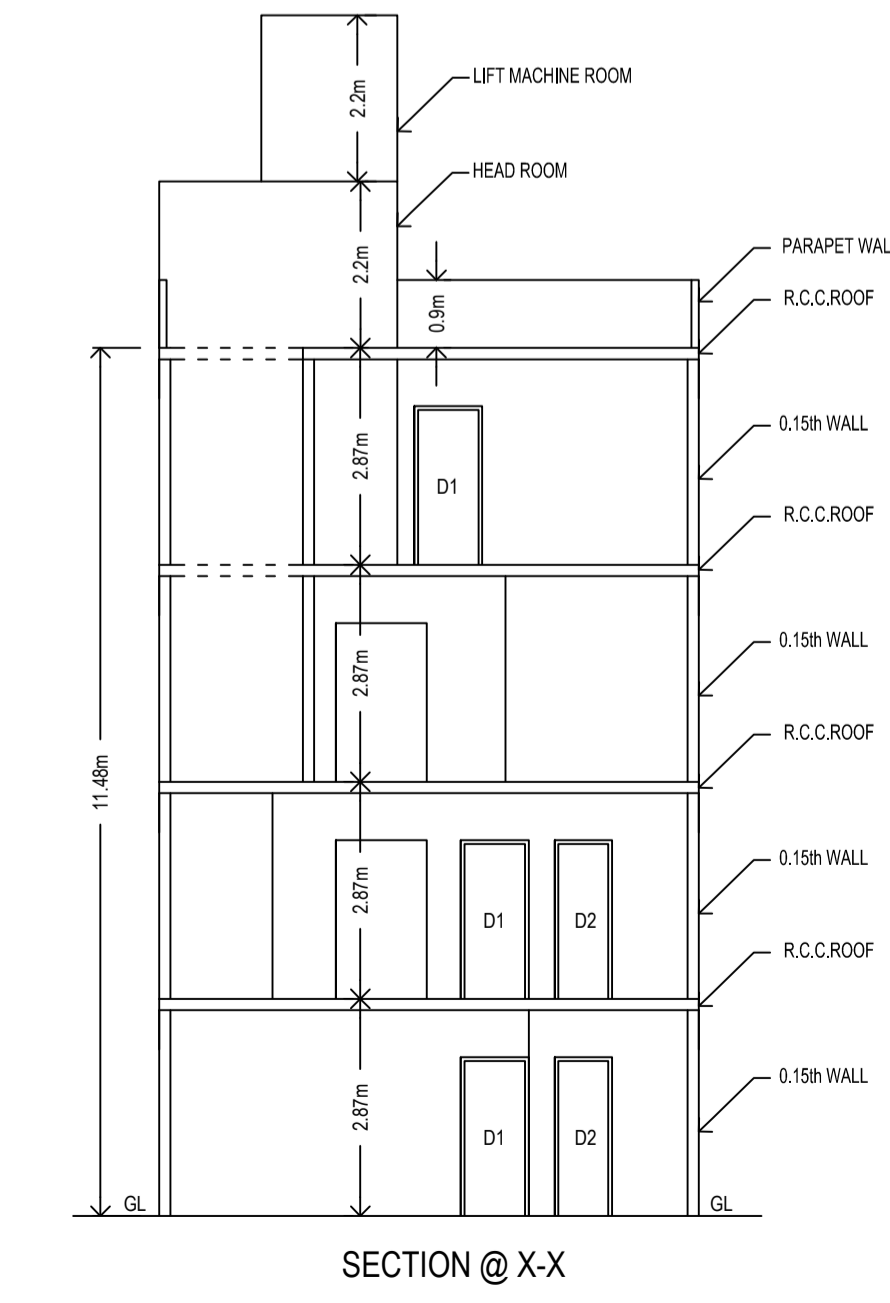
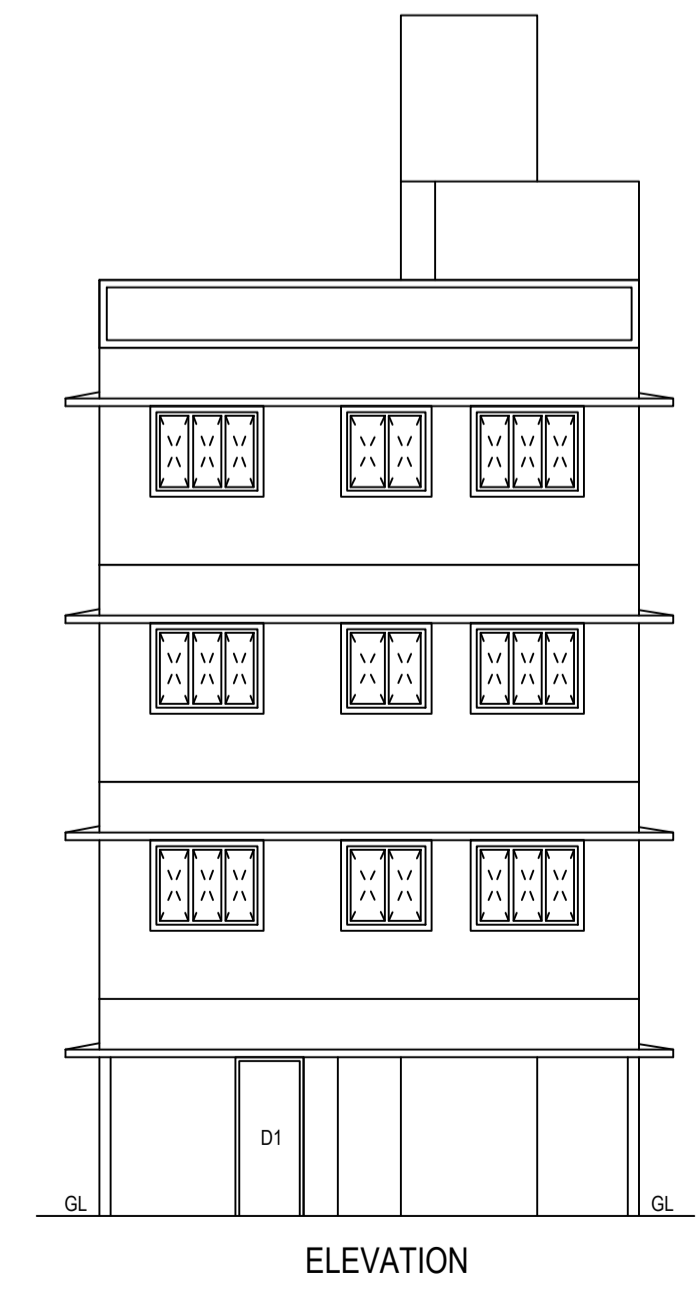

Table with 7 columns: FLOOR, Name, Unit/BUA Type, Unit/BUA Area, Carpet Area, No. of Rooms, No. of Tenement. Rows include First, Second, and Third floor plans.



Block A (KAUSALYA) table with 10 columns: Floor Name, Total Built Up Area, Deductions (Area in Sq.mt.), Proposed FAR Area, Total FAR Area, Tmt (No.), Carpet Area other than Tenement. Rows include Terrace, Third, Second, First, and Ground floors.

SCHEDULE OF JOINERY table with 5 columns: BLOCK NAME, NAME, LENGTH, HEIGHT, NOS. Rows include A (KAUSALYA) for D2, D1, D, and MD.

SCHEDULE OF JOINERY table with 5 columns: BLOCK NAME, NAME, LENGTH, HEIGHT, NOS. Rows include A (KAUSALYA) for V, W1, and W.

Approval Condition: This Plan Sanction is issued subject to the following conditions: 1. The sanction is accorded for... 2. The sanction is accorded for Plotted Resi development A (KAUSALYA) only... 3. Car Parking reserved in the plan should not be converted for any other purpose...

31. Sufficient two wheeler parking shall be provided as per requirement. 32. Traffic Management Plan shall be obtained from Traffic Management Consultant for all high rise structures which shall be got approved from the Competent Authority if necessary. 33. The Owner / Association of high-rise building shall obtain clearance certificate from Karnataka Fire and Emergency Department every two years with due inspection by the department regarding working condition of Fire Safety Measures installed...

Approval Date:

OWNER / GPA HOLDER'S SIGNATURE: OWNER'S ADDRESS WITH ID NUMBER & CONTACT NUMBER: SMT. KAUSALYA RAJU, # 967, 8TH MAIN, 9TH A CROSS, WOC ROAD 2ND STAGE, MAHALAKSHMIPURAM, BANGALORE.

ARCHITECT/ENGINEER /SUPERVISOR'S SIGNATURE: MALLU MADHUSUDHAN REDDY #2, LEVEL 2, SB COMPLE NEXT TO IYER SCHOOL, HMT MAIN ROAD, MATHIKERE, BCC/BL-3/E-4003/2014-15

PROJECT TITLE: PLAN SHOWING THE PROPOSED RESIDENTIAL BUILDING AT SITE NO-1193, W O C ROAD, 2ND STAGE, BASAVESHWARA NAGAR, NAGAPURA, BANGALORE, WARD NO-67(14), P.I.D NO - 14-74-1193

DRAWING TITLE: 1677423708-20-04-202109-05-065, \$ KAUSALYA, RAJU :: A (KAUSALYA) with GF+3UF

SHEET NO: 1

This approval of Building plan/ Modified plan is valid for two years from the date of issue of plan and building licence by the competent authority.